

Table of contents

Article numbers	page 3
Packing details	page 4
Bill of materials	page 5
Assembly and use	page 6
Dimensions	page 7
Specifications	page 10
Safety & test	page 11

Article numbers

Article number	EAN code
DF015 1SXX1	5 708499 111621

Ordering example

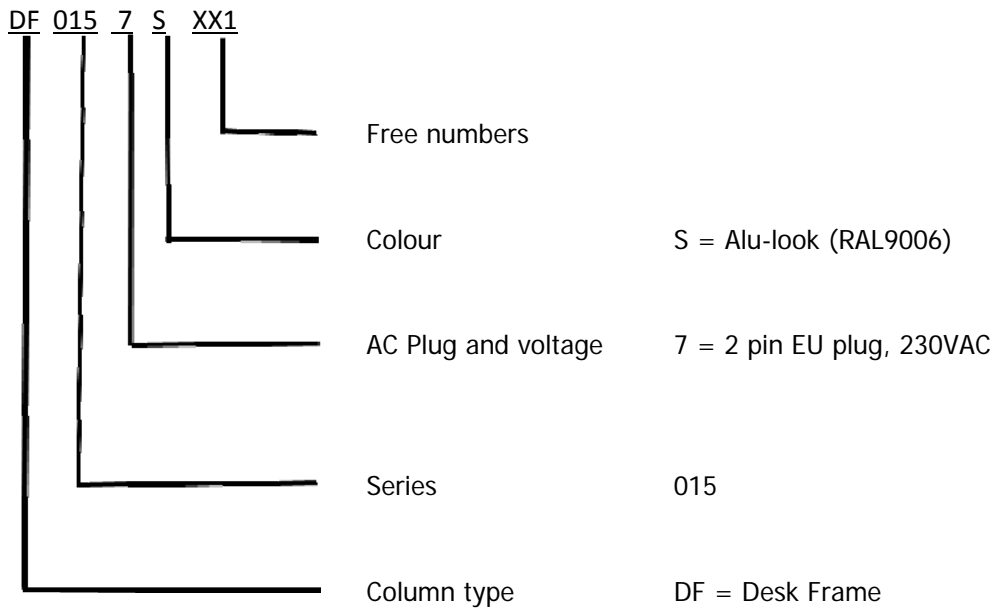

Packing details

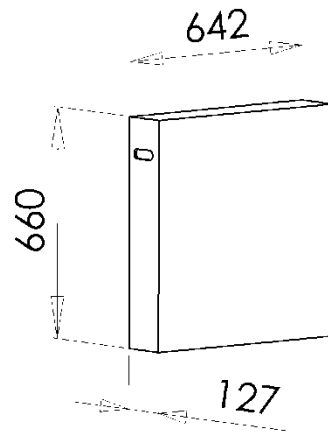

1 pcs.

20 kg

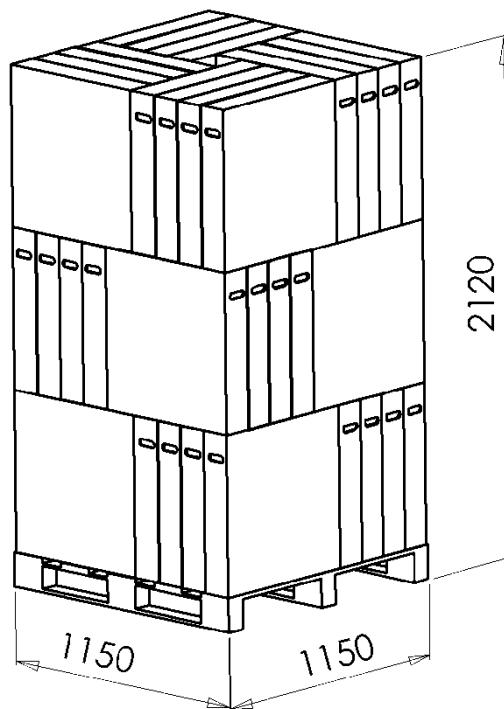

48 pcs.

1000 kg

Bill of material

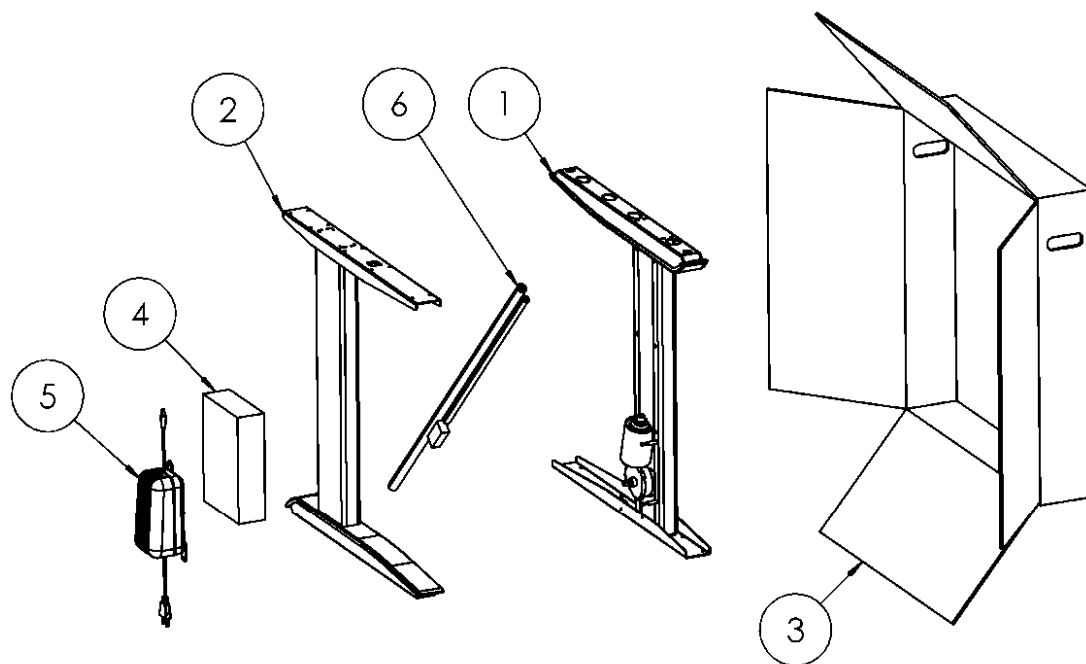

ITEM NO.	QTY.	PART NO.	DESCRIPTION
1	1	106750	Right leg assembly
2	1	106760	Left leg assembly
3	1	310150	Cardboard box
4	1	107260	501-15 overall Mounting bag
5	1	107350	Power supply assembly
6	1	109900	Adjustable tube, packed

Assembly and use

All products come with an instruction manual.

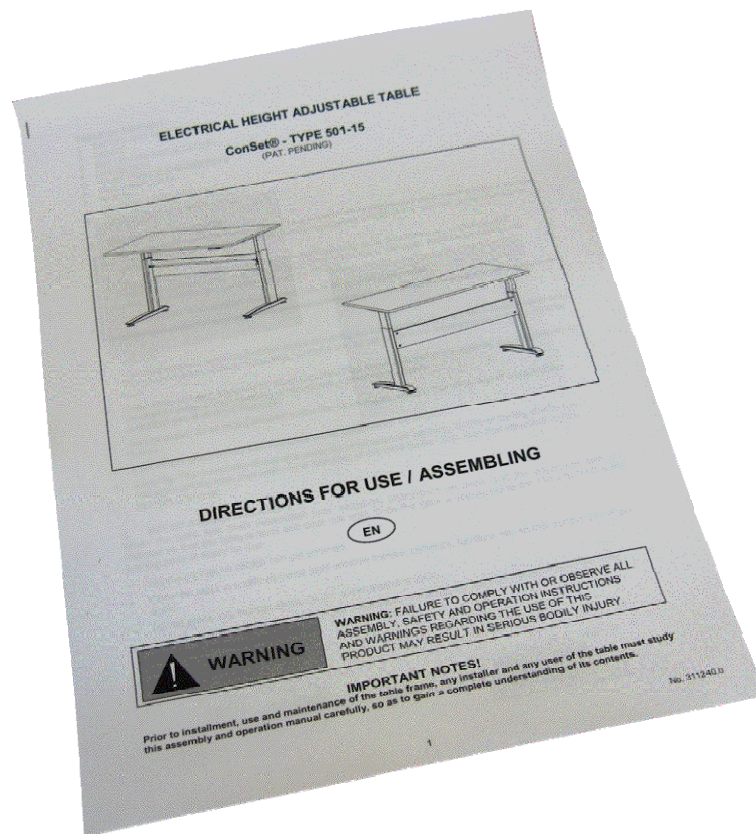

The operation unit has two rocker switches.

With rocker switch A and B it is possible to move the tabletop up and down, and can be stopped at all levels. For safety reasons it is necessary to push both buttons at the same time for moving the table up and down.

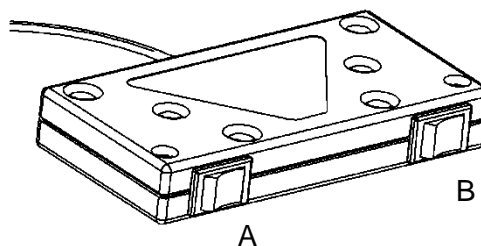

Dimensions

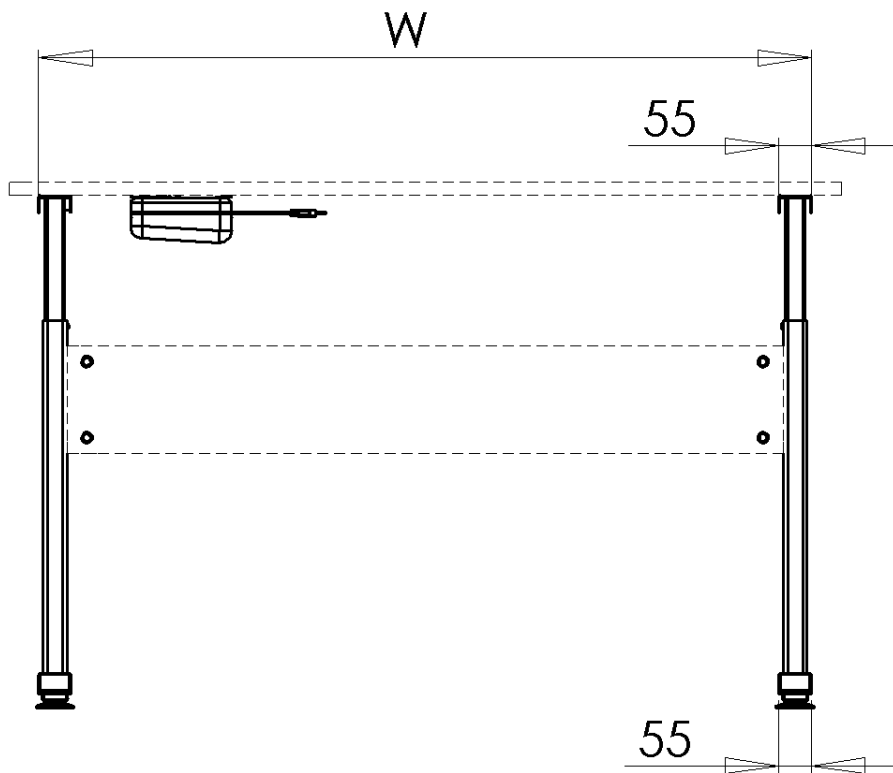
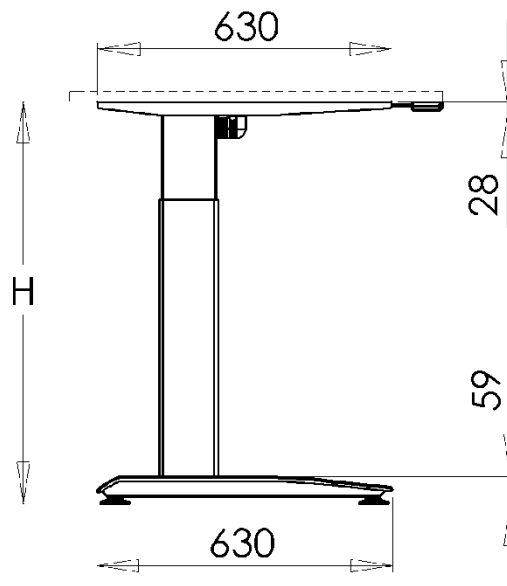

THE INFORMATION CONTAINED IN THIS DRAWING IS THE SOLE PROPERTY OF CONSET A/S. ANY REPRODUCTION IN PART OR WHOLE WITHOUT THE WRITTEN PERMISSION OF CONSET A/S IS PROHIBITED.

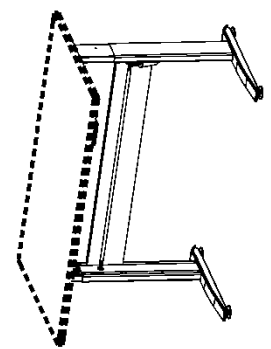
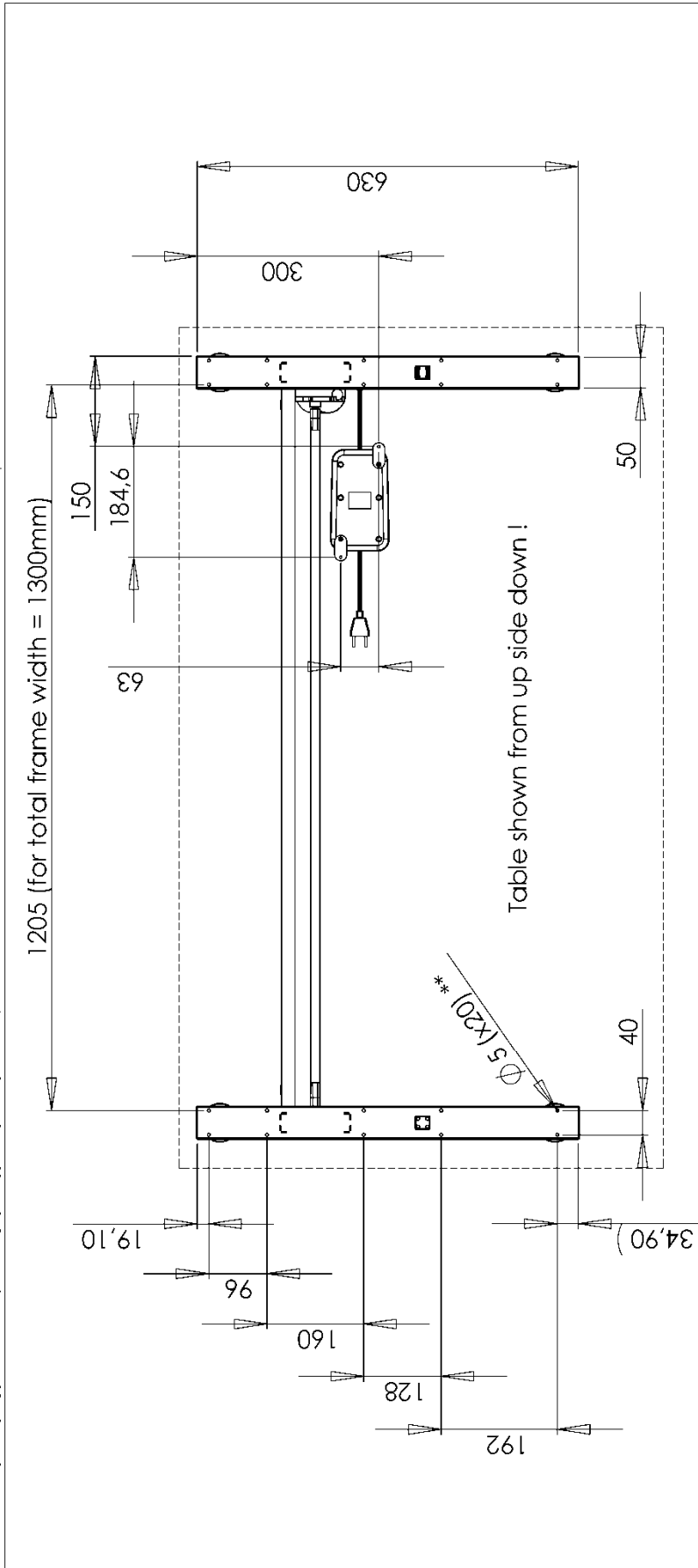

UNLESS OTHERWISE SPECIFIED: DIMENSIONS ARE IN MM TOLERANCES ARE: According to DIN 7186m	MATERIAL SPECIFICATION: ...	Conset A/S Sticvej 14-6 8900 Skjern Denmark
	PROCESS SPECIFICATION: ...	Tabletop spec., 501-15
MATERIAL:		
FINISH:		
DO NOT SCALE DRAWING	DRAWN: JO CHECKED: GL DATE: 06/07/	310032
		REV. 2



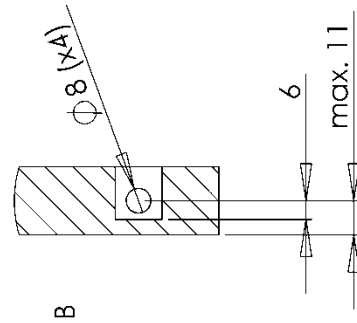
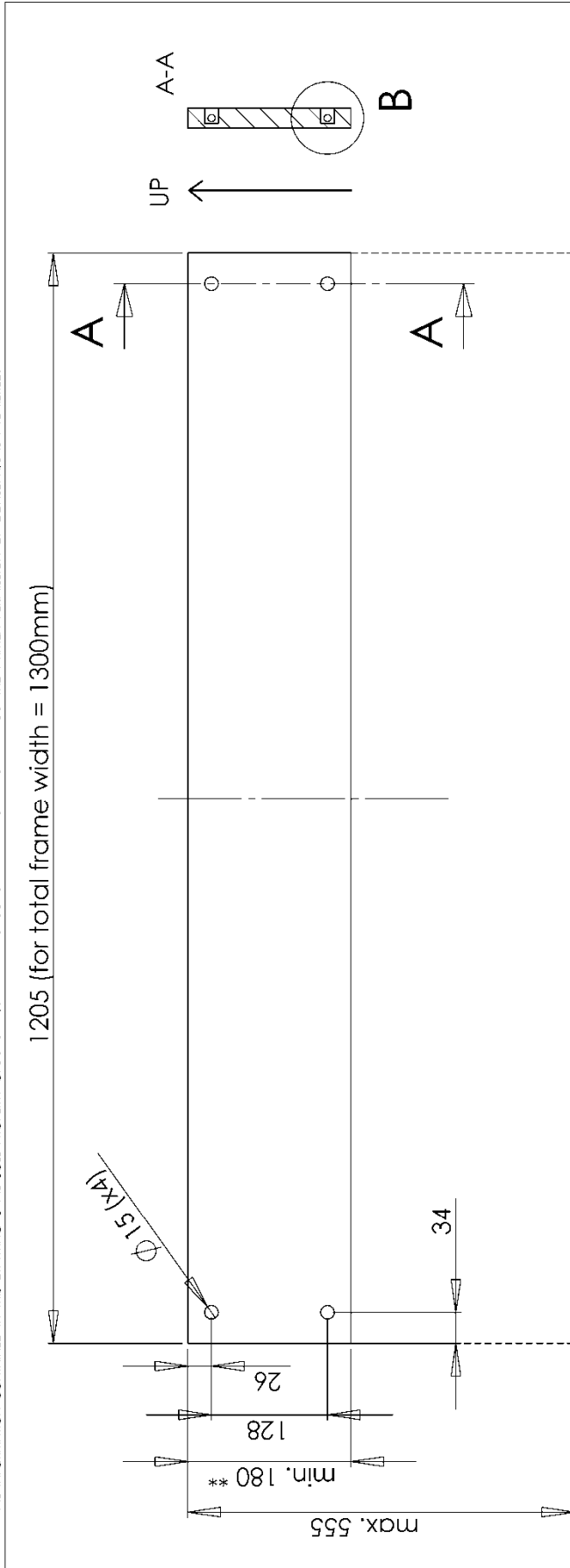

THE INFORMATION CONTAINED IN THIS DRAWING IS THE SOLE PROPERTY OF CONSET A/S. ANY REPRODUCTION IN PART OR WHOLE WITHOUT THE WRITTEN PERMISSION OF CONSET A/S IS PROHIBITED.

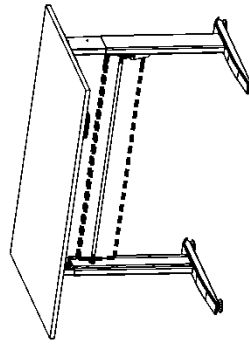

** the min. height gives a symmetric travers !

carrier tube length = 1158mm



UNLESS OTHERWISE SPECIFIED DIMENSIONS ARE IN MM TOLERANCES ARE: According to DIN 7168-m	MATERIAL SPECIFICATION: Støtubes 1,41,16 4000 S12sm Denmark
 MATERIAL FINISH	Conset A/S Lower travers spec., 501-15
DO NOT SCALE DRAWING	DRAWN: JO CHECKED: GL DATE: 06/07/
	REV. 1 310021

Specifications

Columns

Height, frame only	66 – 118 cm
Lifting capacity, frame	70 kilos
Speed	25 mm/sec
Width	123 – 190 cm (if cutting the adjustable tube, width down to 45 cm possible)

Component

Metal sheet parts:	St 37-2
Gear parts:	St 70-2
Gear motor:	CS no. 300047
Power supply:	60 W AC Power Transformer
	Consumption: 60 Watts; Standby: 0,01 Watts
Plastic components:	PEHD, POM
Surface treatment	Visible metal parts powder coated in "alu" colour RAL 9006
	Non visible metal parts are surface treated (e.g. plated)

Safety & Test

DECLARATION OF CONFORMITY

We hereby declare, under our sole responsibility that the following products:

- ConSet sit and stand tables product type 501-15

which are covered by this statement, are in conformity with the following standards and other normative documents::

- Counsel Directive 98/37/EF
- Counsel Directive 89/336/EØF with later changes
- Counsel Directive 73/23/EØF with later changes

With reference to the Machinery Directive (98/37/EF) please be aware:

- the sit and stand table is considered a machine and
- the sit and stand table may not be used until it has been assembled and installed according to the instructions.